



# Shunt capacitor placement in radial distribution networks considering switching transients decision making approach



Mohammad Sadegh Javadi<sup>a</sup>, Ali Esmael Nezhad<sup>b</sup>, Pierluigi Siano<sup>c,\*</sup>, Miadreza Shafie-khah<sup>d</sup>, João P.S. Catalão<sup>d,e,f</sup>

<sup>a</sup> Department of Electrical Engineering, Shiraz Branch, Islamic Azad University, Shiraz, Iran

<sup>b</sup> Young Researchers and Elite Club, Shiraz Branch, Islamic Azad University, Shiraz, Iran

<sup>c</sup> Department of Industrial Engineering, University of Salerno, Fisciano, Italy

<sup>d</sup> C-MAST, University of Beira Interior, R. Fonte do Lameiro, 6201-001 Covilhã, Portugal

<sup>e</sup> INESC TEC and Faculty of Engineering of the University of Porto, R. Dr. Roberto Frias, 4200-465 Porto, Portugal

<sup>f</sup> INESC-ID, Instituto Superior Técnico, University of Lisbon, Av. Rovisco Pais, 1, 1049-001 Lisbon, Portugal

## ARTICLE INFO

### Article history:

Received 1 November 2016

Received in revised form 28 April 2017

Accepted 3 May 2017

### Keywords:

Shunt capacitors

Switching transients

Multi-objective optimization

Iterative power flow

Local search technique

Non-dominated sorting genetic algorithm

## ABSTRACT

This paper provides a new approach in decision making process for shunt capacitor placement in distribution networks. The main core of the evaluation process is a multi-objective framework to allocate the capacitor banks. The power loss and the total harmonic distortion (THD) are the objective functions of the system under study in a long-term planning horizon. In order to select the executive plan introduced by using a multi-objective model, transient switching overvoltages have been considered. As the size and location of shunt capacitors may result in unacceptable overvoltages, the proposed technical decision making framework can be applied to avoid corresponding damages. In this paper, an iterative conventional power flow technique is introduced. This technique can be applied to evaluate THD for distribution networks as well as other power flow based objectives, such as power losses calculation and voltage stability assessment. The presented framework is a two stage one where at the first stage, a non-dominated sorting genetic algorithm (NSGA-II) augmented with a local search technique is used in order to solve the addressed multi-objective optimization problem. Then, at the second stage, a decision making support technique is applied to determine the best solution from the obtained Pareto front. In order to evaluate the effectiveness of the proposed method, two benchmarks are addressed in this paper. The first test system is a 9-bus distribution network and the second one is an 85-bus large scale distribution network. The simulation results show that the presented method is satisfactory and consistent with the expectation.

© 2017 Elsevier Ltd. All rights reserved.

## 1. Introduction

Static reactive power compensation carried out by installing capacitor banks has a solid background in power distribution network compensation. Indeed, at the sub-transmission and distribution voltage levels, application of switched capacitor banks has been generally adopted. In particular, capacitors have been commonly used to provide reactive power compensation in distribution systems. Earlier approaches for addressing the capacitor placement problem differ in both the problem formulation and the solution methods. In some approaches, the savings due to energy losses reduction and peak power losses reduction against the capacitor cost are considered as the objective function in an

unconstrained optimization. Other researches formulated the problem with some variations of the above objective function and some of them have also formulated the problem as a constrained optimization and have considered voltage constraints [1].

Management of the switched capacitor banks has a vital role in order to achieve power and energy losses reduction, system capacity release and acceptable voltage profile, in the operation horizon. However, the extent of these benefits depends upon the location, size, type and the number of the capacitors as well as their control settings [2]. In the planning stage, determination of optimal size, location and type of capacitor banks are the discrete design decision variables. Although the planning variables of these assets are discrete, they may have a direct impact on the continuous variables, such as bus voltage and loss [3].

Power factor correction is normally achieved by the addition of capacitors to the electrical network which are able to compensate

\* Corresponding author.

E-mail address: [siano.pierluigi@gmail.com](mailto:siano.pierluigi@gmail.com) (P. Siano).

the reactive power demand of the inductive loads and thus reduce the burden on the supply without any effect on the operation of the equipment [4]. However, installation of each reactive compensation devices may result in enhanced power quality, reliability and other issues.

The benefits that can be achieved by applying the proper power factor correction are:

- Environmental benefit: reduction of power consumption due to improved energy efficiency.
- Reduced power consumption means less greenhouse gas emissions and fossil fuel depletion by power stations.
- Reduction of the electricity bills
- More active power would be attained from the distribution assets.
- Reduction of active power losses in transformers and distribution equipment.
- Reduction of voltage drop in long cables
- Extended equipment life due to the reduced electrical burden on cables and electrical components.

Combinations of the circuit parameters leading to the maximum over voltages are determined in compliance with the analytical research of voltage magnification, as performed in Ref. [5]. According to the analysis, the phenomenon of voltage magnification occurs when two series connected LC loops have the same natural frequency. The results of the aforementioned analysis (further referred to as the traditional approach) have been adopted in technical literature [6]. Numerical studies of the voltage magnification performed in Refs. [7,8] which enabled to calculate the combinations of the circuit parameters that lead to the maximum over voltages.

It is also worth noting that high transient currents can occur with values higher by ten times than the capacitor nominal current with a duration of several milliseconds [9]. Several parameters that can determine the maximum inrush current have been analyzed in Ref. [10], such as pole spread, the dumping resistor inserted in the current limiting reactor, natural frequency and saturation of the current limiting reactor [11].

However, there are many research works devoted to capacitor placement problem as a vital issue in distribution networks. In this regard, Ref. [12] implemented the above-mentioned problem in order to reduce the power losses as well as improving the voltage profile using ant colony optimization algorithm. Ref. [13] proposes a two-stage framework for locating and sizing of capacitors in radial distribution systems where the loss sensitivity factors are used in the first stage to determine the candidate buses and in the second stage, flower pollination algorithm is used to specify the locations of capacitors among the buses selected in the first stage. It is noted that an improved harmony search algorithm along with power loss index has been employed in Ref. [14] for the capacitor placement in distribution systems. Besides, an optimization technique based on plant growth has been utilized in Ref. [15] to optimally locate the capacitor in power systems. Another research work investigating the optimal capacitor placement in distribution network is Ref. [16] where the problem has been solved using enhanced bacterial foraging optimization while the thermal re-rating of critical cables has been precisely modeled. Furthermore, penalty free genetic algorithm has been used in Ref. [17] for locating and sizing capacitors in distorted distribution systems which include different load models. It should be noted that all these research works have proposed a single objective framework for capacitor placement in distribution systems. However, it is noted that there are some uncertain parameters within the context of capacitor placement problem in distribution networks such as load demand and renewable power generation. In this

regard, a comprehensive study on different methods has been carried out in Ref. [18].

The main contributions of this paper are as follows:

- (1) Proposing a novel framework for Bi-objective Shunt capacitor placement
- (2) Evaluating the Pareto solutions by analyzing the transient overvoltages
- (3) Proposing a two-stage framework for the problem of shunt capacitor placement
- (4) Employing NSGA-II augmented with a local search to find the Pareto solutions

This paper is organized as follows: in Section 2, the iterative distribution power flow is presented where the classic distribution power flow is modified to address the different types of loads by adopting the successive substitution technique. Section 3 provides the capacitor placement in radial networks. This section addresses the capacitor placement problem as a multi-objective optimization problem considering the power losses and the total harmonic distortion. Section 4 includes the descriptions on the augmented non-dominated sorting genetic algorithm used as the local search technique to determine the optimal Pareto front for the capacitor placement problem. The optimal Pareto set would be then evaluated by using a decision making technique. The transient overvoltage due to capacitor switching in the distribution network is considered for the decision making process in Section 5. Simulation results for the two case studies are provided in Section 6 to evaluate the feasibility and optimality criterion. Conclusion remarks are addressed in the last section.

## 2. Iterative distribution power flow

The Backward-Forward power flow method has been addressed in the literature to perform distribution load dispatch. As the mentioned model has been proposed for the usual frequency of 50–60 Hz, the implementation of such a technique to consider the harmonic power flow needs to be revised. The method proposed in this paper is based on classical Newton-Raphson power flow algorithm and considers the recursive equations to update the results in the presence of voltage dependent load models. The effects of various load models on the convergence pattern of the method have been verified. As the real distribution networks have several laterals and branches, it is needed to apply a fast and reliable technique with a fair convergence trend to perform the distribution power flow. The proposed successive substitutive power flow method confirms that the convergence ability of the proposed method is acceptable when compared with Ratio-Flow method, which is known for its faster convergence characteristics amongst various sweep methods [19]. In the successive power flow method, the obtained results are used to update the active and reactive demanded power at each load center. As the demanded loads are considered to be voltage dependent, it is needed to iteratively update the active and reactive power.

Since the nature of commercial, industrial and residential loads is such that their active and reactive powers are dependent on the voltage and frequency of the system, it is needed to provide a model which is able to handle these issues. In this study, for voltage depended loads, the power flow model is solved by a successive power flow method and in order to calculate the total harmonic distortion, the modified power flow algorithm should be implemented by taking into consideration the other harmonic orders. Common static load models for active and reactive power are expressed in a polynomial or an exponential form. The characteristic of the exponential load models can be given as:

$$P_{li} = P_{li}^{(0)} \left( \frac{V_{li}}{V_{li}^{(0)}} \right)^{n_p} \quad (1)$$

$$Q_{li} = Q_{li}^{(0)} \left( \frac{V_{li}}{V_{li}^{(0)}} \right)^{n_Q} \quad (2)$$

where  $n_p$  and  $n_Q$  stand for load exponents,  $P_{li}^{(0)}$  and  $Q_{li}^{(0)}$  stand for the values of the active and reactive powers at the nominal voltages for load  $l$  located at bus  $i$ , respectively.  $V_{li}$  and  $V_{li}^{(0)}$  stand for bus voltage and bus nominal voltage, respectively. Special values of  $n_p$  and  $n_Q$  can cause specific load types such as: 0, constant power; 1, constant current; 2, constant impedance. The polynomial load model is a static load model that represents the power–voltage relationship as a polynomial equation of voltage magnitude. It is usually referred as ZIP model, since it is made up of three different exponential load models: constant impedance (Z), constant current (I) and constant power (P) static load models.

Common values for exponents of static loads are given in Table 1 [20–22]. For practical applications, the evaluation of coefficients  $n_p$  and  $n_Q$  requires the use of parameter estimation techniques.

In power flow studies, by incorporation of each common technique used to solve the load flow, such as Newton-Raphson, Gauss-Seidel and backward-forward techniques, the successive method could be implemented in order to determine the problem variables, such as power flow direction, branch current, node voltage and so on. In the successive power flow technique, the replacement of decision variables (node voltages) should iteratively be performed to maintain the acceptable absolute error. In this study, for the fundamental frequency (50–60 Hz), the load flow calculation has been performed by implementing the classical Newton-Raphson model.

The power flow equations for active and reactive power are as follows:

$$P_{li} - \sum_{j=i-1}^{i+1} |Y_{ji}^1| |V_j^1| |V_i^1| \cos(\delta_i^1 - \delta_j^1 - \theta_{ji}^1) = 0 \quad i = 1, 2, \dots, m \quad (3)$$

$$Q_{li} - \sum_{j=i-1}^{i+1} |Y_{ji}^1| |V_j^1| |V_i^1| \sin(\delta_i^1 - \delta_j^1 - \theta_{ji}^1) = 0 \quad i = 1, 2, \dots, m \quad (4)$$

where  $Y_{ji}^1$  is the element  $ji$  of the bus admittance matrix based on fundamental frequency;  $\delta$  is the voltage angle;  $\theta_{ji}^1$  is the corresponding angle of element  $Y_{ji}^1$ . The superscript denotes the fundamental frequency.

The voltage at node  $i$  and  $j$  are addressed by  $V_i^1$  and  $V_j^1$ , respectively. The Y-bus matrix for a given network can be arranged as follows:

**Table 1**  
Common values for the exponents for different static load models [19].

Load component	$n_p$	$n_Q$
Battery charge	2.59	4.06
Fluorescent lamps	2.07	3.21
Constant impedance	2	2
Fluorescent lighting	1	3
Air conditioner	0.5	2.5
Constant current	1	1
Resistance space heater	2	0
Pumps, fans other motors	0.08	1.6
Incandescent lamps	1.54	0
Compact fluorescent lamps	1	0.35
Small industrial motors	0.1	0.6
Large industrial motors	0.05	0.5
Constant power	0	0

$$Y_{ji}^1 = |Y_{ji}^1| \angle \theta_{ji}^1 = \begin{cases} -y_{ji}^1 & j \neq i \\ y_{j-1,i}^1 + y_{j+1,i}^1 + y_{ci}^1 & j = i \end{cases} \quad (5)$$

where the  $y_{ji}^1$  is the admittance of line section between buses  $j$  and  $i$  while  $y_{ci}^1$  is the admittance of shunt capacitor at bus  $i$  at the fundamental frequency. The power losses between nodes  $i$  and  $i+1$  can be calculated by:

$$P_{loss(i,i+1)}^1 = R_{i,i+1} \left( |V_{i+1}^1| - |V_i^1| |y_{i,i+1}^1| \right)^2 \quad (6)$$

As the power factor correction obtained by implementing the capacitor banks placement in distribution networks would reduce the power losses, the benefits of the loss reduction due to such assets should be considered in the objective cost function. In this paper, one of the objective functions aimed to be minimized is represented by the power losses. The impacts of reducing power losses can affect the operational cost in the planning horizon. It is noted that the impacts of the power losses can be considered in the objective function both as minimizing the annual power losses and also as the maximization of the savings due to the power losses reduction. However, it should be considered that the form used in this paper is for the sake of comparison. Furthermore, it is note-worthy that the first part of the simulation includes the optimal power flow in order to obtain the Pareto optimal solutions of the problem, i.e. the possible plans. This part employs a static power flow. After obtaining the optimal Pareto solutions, it is time to select the most compromise solutions. In this respect, this manuscript uses a transient study of all Pareto solutions using Electromagnetic Transient Program (EMTP) to choose the solution with the best transient performance. This part plays the decision making role in the problem.

### 3. Capacitor placement in radial networks

The issue of capacitor placement in radial distribution networks is a well-known problem. In order to evaluate the feasibility of the mentioned problem, some benchmarks have been addressed in the literature [23]. The general distribution system capacitor placement problem consists of determining the optimal location, type, and size of capacitors such that the power and energy losses are minimized while taking the cost of capacitors into account [24]. In recent research studies, the effects of harmonic distortion in the presence of capacitor banks have been studied [25]. The total harmonic distortion index has been considered as a constraint in the previous studies.

In this paper, the  $THD_{max}$  is considered as an objective function together with the power losses. One of the effects of capacitor placement in the radial networks is energy loss reduction influencing the operational cost. Also, the optimal capacitor placement maintains the voltage profile in an acceptable margin. The steady state voltage limitations are considered as constraints and should remain between the permitted range.

The capacitor placement problem in a multi-objective problem is stated as follows:

$$\text{Minimize } [f_1, f_2]$$

where

$$\begin{cases} f_1 = F_{Loss} \\ f_2 = \text{Max}(THD_i^{voltage}) \end{cases} \quad (7)$$

s.t.

$$F_{Cap} (\$/Year) \leq Budget$$

The first objective function aims to minimize the power loss,  $F_{Loss}$ , and the second objective function is organized to minimize the maximum THD observed at entire nodes of distribution net-

work in presence of capacitor banks, while the annual investment cost has been limited. It is noted that the cost of supplying load demand is assumed to be fixed since the distribution system considered is radial and the price of energy is fixed, as well. Besides, the energy tariff is considered to be fixed and does not vary with the consumption. Thus, minimizing the cost of supplying load has not been considered in the objective function. It is worth noting that the consideration of the investment cost as one of the constraints has been considered in order to limit the number of shunt capacitors placement in distribution networks. Not considering this constraint may generate, in fact, a solution involving high number of capacitors that will not be justified by a modest increase in other objective functions. So, the number of installed shunt capacitors should be compared to the benefits they bring in terms of other factors such as power losses, THD, and so on.

There are several research works considering the THD as a constraint when considering the placement of shunt capacitors. This paper also considers the THD as the second objective function enabling the decision maker to evaluate different plans. Moreover, it should be noted that after obtaining the optimal Pareto fronts (optimal plans), it is considered that THDs above 10% are not acceptable in the first case study, while in the second case study, it is assumed that THDs above 5% are unacceptable. It should be noted that the voltage of buses is a constrained variable between 0.9 p.u. and 1.1 p.u in the considered problem, so it is not necessary to add another objective function related to voltages at buses.

The capacitors' size, capacity and their locations are discrete decision variables. It is noted that the term "size" refers to the capacity of each capacitor unit which are assumed to be available in 150 kVAr utmost and the term "capacity" refers to the total capacity of capacitors needed to be installed. The maximum size of capacitor banks are a multiple of the smallest size  $Q_0^c$  as follows:

$$Q_{\max}^c = LQ_0^c \quad (8)$$

where  $L$  is an integer coefficient and generally, larger capacitor sizes are cheaper than smaller ones. Therefore, the maximum allowable capacitor size to be placed at any feeder location is limited to  $Q_{\max}^c$ .

Then at each shunt capacitor location, there are  $L$  capacitor sizes  $\{Q_0^c, 2Q_0^c, \dots, LQ_0^c\}$  to choose from. Moreover, the per kVAr investment cost of larger capacitor banks are lower than the associated capital costs for smaller ones. Let  $\{K_1^c, K_2^c, \dots, K_L^c\}$  be their corresponding equivalent annual cost per kVAr. Following the above notation, the annual investment cost function due to capacitor placement is written as:

$$F_{\text{Cap}} = \sum_{j=1}^k K_j^c Q_j^c (\$/\text{Year}) \quad (9)$$

where  $j = 1, 2, \dots, k$  represents the shunt capacitor buses. The simulation results confirm this issue that by installing the capacitor banks in radial distribution networks, the active power losses would be reduced. The main reason of this reduction is due to voltage profile improvement. The amount of power losses has been considered in this paper. However, the cost of power losses can be by multiplying the cost of power losses,  $K^p$ , by the annual loss,  $P_{\text{loss}}^Y$  as following, but the amount of power loss .

$$F_{\text{Loss}} = K^p P_{\text{loss}}^Y (\$/\text{Year}) \quad (10)$$

The annual power loss is the integral of hourly power loss and is defined by:

$$P_{\text{loss}}^Y = \sum_{n=1}^N \left( \sum_{i=0}^{m-1} P_{\text{loss}}^n(i, i+1) \right) \quad (11)$$

where  $N$  is the number of hours over a year, i.e. 8760 h and  $m$  denotes the number of buses while  $i = 0$  indicates the slack bus.

It should be noted that the THD at each node would be attained by implementing the harmonic power flow [25]. By calculating the  $n$ -th order harmonic voltage at node  $i$ , the rms voltage can be calculated by:

$$|V_i| = \sqrt{\sum_{n=1}^N |V_i^n|^2} \quad (12)$$

The corresponding THD for voltage is therefore as follows:

$$\text{THD}_i^{\text{voltage}} (\%) = \frac{\sqrt{\sum_{n \neq 1}^N |V_i^n|^2}}{V_i^1} \times 100 \quad (13)$$

In this study, the objectives of placing shunt capacitors along distribution feeders is to reduce the total power loss and to minimize the maximum THD at entire buses while bringing the bus voltages within the prescribed limits.

$$V_{\min} \leq |V_i| \leq V_{\max} \quad (14)$$

where  $V_{\min}$  and  $V_{\max}$  correspond to the permissible minimum and maximum rms voltage in the system under study, respectively.

#### 4. Non-dominated Sorting genetic algorithm (NSGA-II) augmented by local search

The Elitist Non-dominated Sorting Genetic Algorithm is presented in [26]. The NSGA-II uses not only an elite-preserving strategy but also an explicit diversity-preserving mechanism. NSGA-II provides an efficient procedure for introducing elitism into multi-objective evolutionary algorithms while guaranteeing a diversity-preserving mechanism, assuring in this way a good convergence towards the Pareto-optimal front without losing solution diversity. In this paper, the classical NSGA-II is augmented by local search algorithm. The main features of local search technique adopted in reactive power planning, especially in capacitor placement has been addressed in [27]. The enhanced NSGA-II approach couples a local search scheme to the standard NSGA-II, which is adapted to the characteristics of the VAR planning problem in radial networks. In this problem the main decision variables refer to the identification of the network nodes to install capacitors and the dimension of each capacitor to be installed aimed at minimizing system losses, while keeping an adequate voltage profile and satisfying physical laws in electrical networks. The chromosome structure is divided into two parts of equal lengths. The first part of the chromosome keeps the identification of the nodes where capacitors should be located for that specific solution. The second part of the chromosome holds the capacitor sizes that are located at the network nodes described in the first part. In this research, we consider that the capacitor location is limited to pre-defined nodes. In other words, the first part decision variables are binary variables. However, the proposed method can solve the optimization models in which the first part of chromosome has integer decision variables. The proposed model can be implemented in the generation and transmission expansion planning problem in which the decision variables are the same as the capacitor placement problem. As the second part of chromosomes is associated with the size of capacitors, it is needed to adopt a mapping procedure to map the corresponding capacitor from the list.

The continuous decision variables (active power, reactive power and node voltage) in the mathematical model are computed using the addressed iterative power flow algorithm, which is invoked once a solution configuration is established (the size of capacitor to be installed in each network node).

A new population  $E_0$  is obtained using binary tournament selection crossover and mutation. Before combining together the parent and offspring populations, the local search procedure is applied to



all offspring solutions, trying to adjust the capacity installed. The local search only operates on the second part of the chromosome. In this local search scheme, a move leading to a neighbor solution is defined by changing the capacitor size in the network to a neighbor size. In the proposed local search scheme, the procedure attempts to improve the solution by moving the capacitors' size considering the fact of installing capacitor banks. The local search is adopted for each chromosome if the first part advises to install capacitor banks. As the second part of chromosome is under the local search, it is possible to reduce the size of chromosome to the second part. In order to reduce the size of chromosome, the first part of chromosome would be merged. In such a case, if the chromosome introduces a non-zero number, it means that at corresponding node we have a capacitor bank, otherwise it is not necessary to perform the local search for that chromosome. By implementing the mapping procedure at this stage, the computational burden would be reduced.

Fig. 1 illustrates the classical mapping procedure to address the chromosome to capacitor placement problem. The modified local search technique addressed in this section is provided in Fig. 2. In this paper, the standard NSGA-II algorithm is modified by considering the addressed local search to determine the optimal Pareto front. A detailed explanation of standard NSGA-II can be found in [26,28].

In the next section, the transient overvoltage due to switching the capacitor banks in the distribution network is addressed. This key factor is then taken into consideration as decision making technique after Pareto front determination by multi-objective optimization model. However, fuzzy satisfying method can be used, as well [29] beside other methods, such as VIKOR, TOPSIS, analytic hierarchy process (AHP) and Analytic network process (ANP).

### 5. Capacitor switching transients

The switching transient overvoltage is a well-known phenomenon appearing at the customer terminals due to capacitor bank switching. The switching transient overvoltages may result in power quality problems and affect the adjustable speed drives, protection devices and communication equipment. Such transient overvoltages should be minimized in the planning and operation stages to maintain the voltage profile in acceptable margins. At the operating horizon, connection and disconnection of capacitor banks should be managed by smart switches to reduce the maximum overvoltages. Resistive switching and inductive switching actions are the conventional methods to mitigate the transient over voltages due to capacitor switching [30].

The peak voltage magnitude of the transient depends upon the instantaneous system voltage at the moment of energizing and under worst-case conditions, this can be up to 2.0 times greater than the normal system peak voltage [31]. But the magnitude is usually less than this value because of system loads and damping phenomenon due to resistive elements in the system [7]. In distribution networks, typical over voltage levels would be between 0.9 and 1.1 p.u [32]. In addition, to the transient overvoltage phenomenon, application of shunt capacitors can lead to the following side effects: Increased transient inrush current in power transformers, and prolonged decay rate of the transient [33]. Severe harmonic distortion, and resonance with load-generated harmonics and capacitors can be stressed due to switching transients [8].

Determination of the maximal magnified overvoltages, which may be applied across the customer terminals, has become an important task for power utility engineers.

As mentioned above, the capacitor bank switching provokes transient overvoltages that theoretically can reach peak phase-to-earth values in the order of 2.0 p.u. Amplified overvoltages in remote capacitor banks due to the oscillatory nature of the coupled circuit can be also generated [5]. Some factors that affect the amplification of the transient voltages during the capacitor banks switching should be also mentioned: the size of the capacitor switched, the short circuit capacity at the location where the capacitor is inserted, the power of the customer's transformer and the characteristics of the customer's load [7]. It is also worth noting that high transient currents can occur, reaching values superior to ten times the capacitor nominal current with duration of several milliseconds [9]. Several parameters that can determine the maximum inrush current have been analyzed in Ref. [10], such as: pole spread, the dumping resistor inserted in the current limiting reactor, natural frequency and saturation of the current limiting reactor.

Some aspects regarding factors that influence the intensity of the transients were: load current value during bank switching, the order in which the utility banks are switched, industry capacitor size, localization of the utility banks along the feeder, pole spread during switching and synchronization of capacitor switching. Finally, a comparison with real-life data recorded at the distribution system has been performed in order to validate the present simulation [11].

Fig. 3 illustrates the single line diagram of single phase test system for switching transient over voltages. In this figure, a simple network has been provided to evaluate the transient voltage due to capacitor switching actions. Three cases are studies in this regard. In the first case, we consider that corresponding  $C_1$  switch named,  $S_1$  located at that branch is closing while the second capacitor's switch,  $S_2$ , is open. In the second case, the closing of the

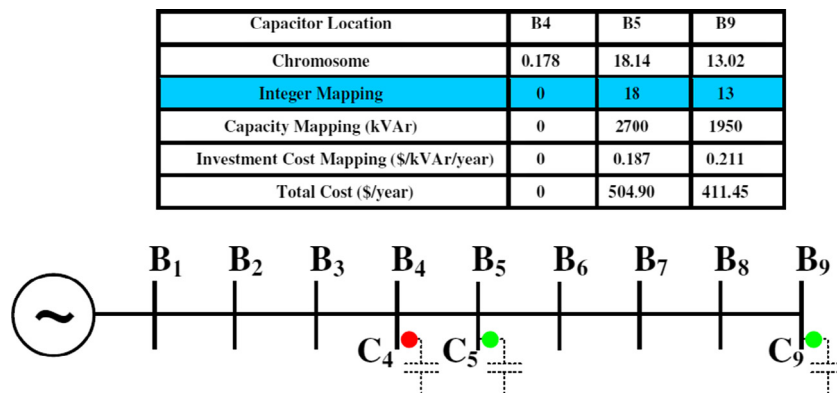

Fig. 1. Classical mapping procedure to address the capacitor placement problem.

Capacitor Location	B4	B5	B9
Integer Mapping	0	18	13
Local Search on B5 (-)	0	17	13
Local Search on B5 (+)	0	19	13
Local Search on B9 (-)	0	18	12
Local Search on B9 (+)	0	18	14

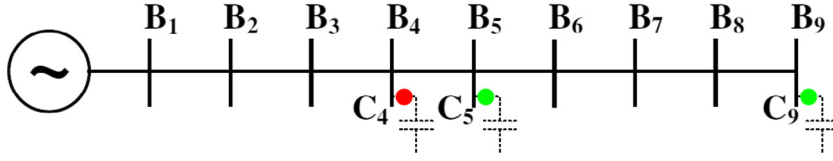

Fig. 2. Modified capacitor placement with local search technique.

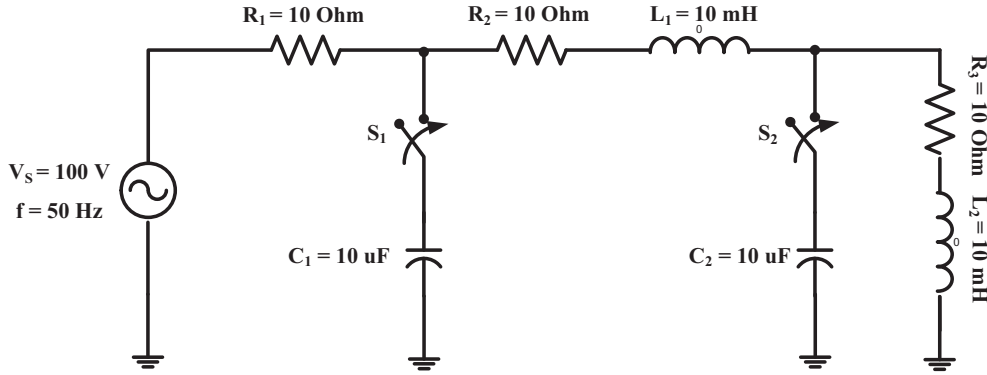

Fig. 3. Single line diagram of single phase simple test system [34].

switch  $S_1$  while the switch  $S_2$  was closed is considered. The last case considers the same scenario in which switch  $S_2$  is going to be closed with switch  $S_1$  already shut. These case studies are provided to model the switched capacitor in line with fixed capacitor operations.

#### Case 1:

The equations for the current and voltage in the capacitor  $C_1$  during the closing of the switch  $S_1$  in Fig. 3, with switch  $S_2$  open, are given, respectively, by [31]:

$$V_{C1}(t) = V - [V - V_{C1}(0)]\cos(\omega_1 t) \quad (15)$$

$$I_{C1}(t) = \frac{V}{Z_1} \sin(\omega_1 t) \quad (16)$$

where  $\omega_1 = \frac{1}{\sqrt{L_1 C_1}}$  is the natural frequency;  $V_{C1}(0)$  initial voltage of  $C_1$ ;  $V$ , switch voltage when  $S_1$  is closed and  $Z_1 = \sqrt{\frac{L_1}{C_1}}$  is the surge impedance.

#### Case 2:

In the second case, closing of the switch  $S_1$ , with switch  $S_2$  already shut, the associated voltage on the remote capacitor  $C_2$  could be extracted as follows:

$$V_{C2} = V[1 + A \times \cos(\phi_1 t) + B \times \cos(\phi_2 t)] \quad (17)$$

in which:

$$A = -\frac{1}{2 \left[ \sqrt{\left(\frac{\omega_1}{2\omega_2} + \frac{\Delta\omega_2}{2\omega_1}\right)^4 - \left(\frac{\omega_1}{2\omega_2} + \frac{\Delta\omega_2}{2\omega_1}\right)^2} - \left(\frac{\omega_1}{2\omega_2} + \frac{\Delta\omega_2}{2\omega_1}\right)^2 - 1 \right]}$$

$$B = +\frac{1}{2 \left[ \sqrt{\left(\frac{\omega_1}{2\omega_2} + \frac{\Delta\omega_2}{2\omega_1}\right)^4 - \left(\frac{\omega_1}{2\omega_2} + \frac{\Delta\omega_2}{2\omega_1}\right)^2} + \left(\frac{\omega_1}{2\omega_2} + \frac{\Delta\omega_2}{2\omega_1}\right)^2 - 1 \right]}$$

$$\phi_1 = \sqrt{\left(\frac{\omega_1^2}{2} + \frac{\Delta\omega_2^2}{2}\right) - \left(\frac{\omega_1^2}{2} + \frac{\Delta\omega_2^2}{2}\right)^2} - \omega_1^2 \omega_2^2,$$

$$\phi_2 = \sqrt{\left(\frac{\omega_1^2}{2} + \frac{\Delta\omega_2^2}{2}\right) + \left(\frac{\omega_1^2}{2} + \frac{\Delta\omega_2^2}{2}\right)^2} - \omega_1^2 \omega_2^2$$

$$\Delta = \left(1 + \frac{C_2}{C_1}\right) \quad \omega_1 = \frac{1}{\sqrt{L_1 C_1}} \quad \omega_2 = \frac{1}{\sqrt{L_2 C_2}}$$

The amplified voltage at the remote capacitor is composed of three components: the source voltage and two oscillatory components  $\phi_1$  and  $\phi_2$ . This phenomenon is known as amplification of the voltage and should be considered in the switching actions. In two L-C loop systems, the maximum transient overvoltage component is found to occur when the natural frequency of each L-C loop is the same.

#### Case 3:

The closing of switch  $S_2$ , with switch  $S_1$  already shut, is considered in this case. In such case, any difference of potential between the two banks is eliminated by a redistribution of load. The equalizing current that flows in the inductance  $L_2$ , is given by [35].

$$I_{C2} = \frac{V_1 - V_{C2(0)}}{\sqrt{L_2 \left[ \frac{C_1 + C_2}{C_1 C_2} \right]}} \sin(\omega_2 t) \quad (18)$$

where

$$\omega_2 = \frac{1}{\sqrt{L_2 \left[ \frac{C_1 C_2}{C_1 + C_2} \right]}}$$

In which,  $V_{C2(0)}$ , is the initial voltage  $C_2$ ; and  $\omega_2$  is the capacitor switching transient results from the energy exchanged between the inductive and capacitive elements in the circuit.

It is worth mentioning that in the radial distribution networks, the resistance of distribution feeders is considerable. Hence, the overvoltage calculation due to switching of capacitor banks would be rogueries. Moreover, the number of feeders of a real distribution networks are remarkable and the calculation of switching transients would be a time consuming process. To alleviate the computational burden, the overvoltage calculations have been performed with computer based packages. One of available commercial package to calculate transients in power systems is the Electromagnetic Transient Program (EMTP). The EMTP package has this ability to simulate large scale power systems and could analyze the steady state as well as transient studies. In the recent versions of this package, EMTP-RV for the power flow analysis is available as an option. In order to verify the simulation results of capacitor switching in a simple network, a two-capacitor single phase test system has been addressed in Ref. [34].

In order to verify the switching over voltage in EMTP-RV with the classical ATP package, there is a need for a suitable baseline for comparison. This baseline is provided by performing manual calculations from first principles.

Transient modeling is conducted by closing the switch to capacitor  $C_2$ , switch  $S_1$  is closed. The ATP and EMTP-RV time domain simulation results of this test system are addressed in Figs. 4 and 5, respectively. As the simulation results are identical, therefore the simulation procedure with the EMTP-RV package is valid.

As mentioned before, one of the key issues in the maximum transient overvoltage due to capacitor switching is the location of these compensators. The size of capacitors also has a critical impact on the overvoltages' natural frequency. At the operation horizon, the initial voltage of capacitors,  $V_C(0)$ , may result in the amplified over voltages during switching actions. As reported in the literature, the worse conditions for capacitor switching would

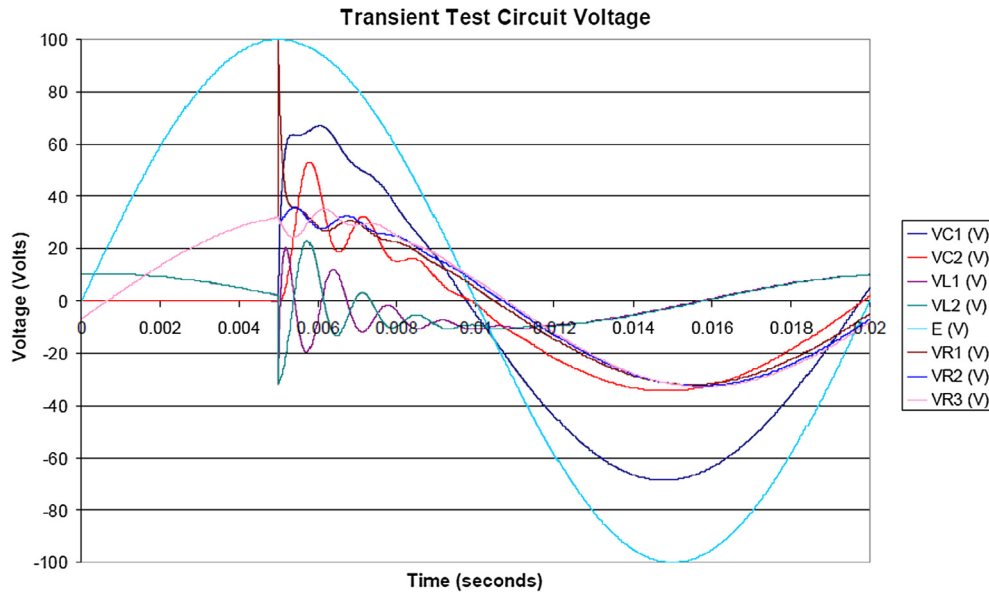

Fig. 4. The worst case capacitor switching at peak voltage (ATP) [34].

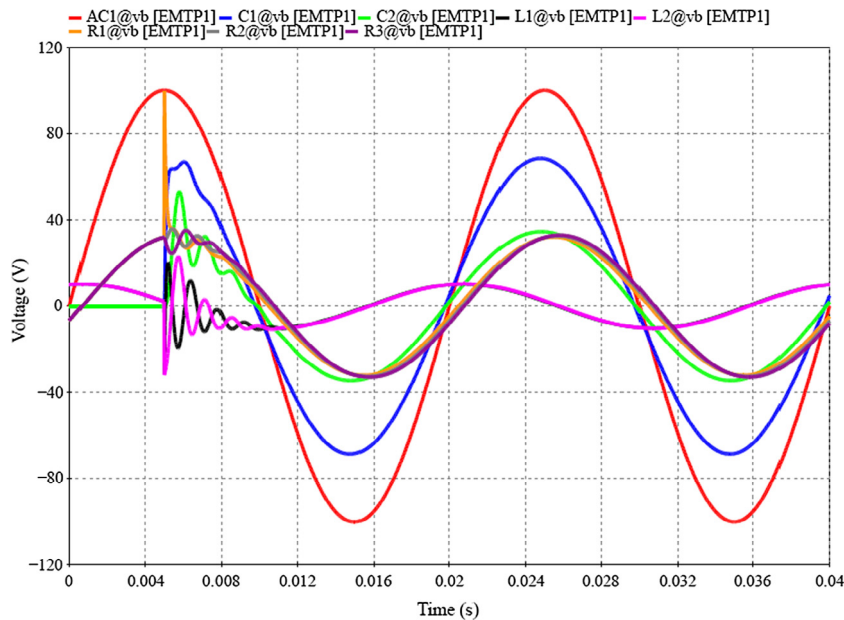
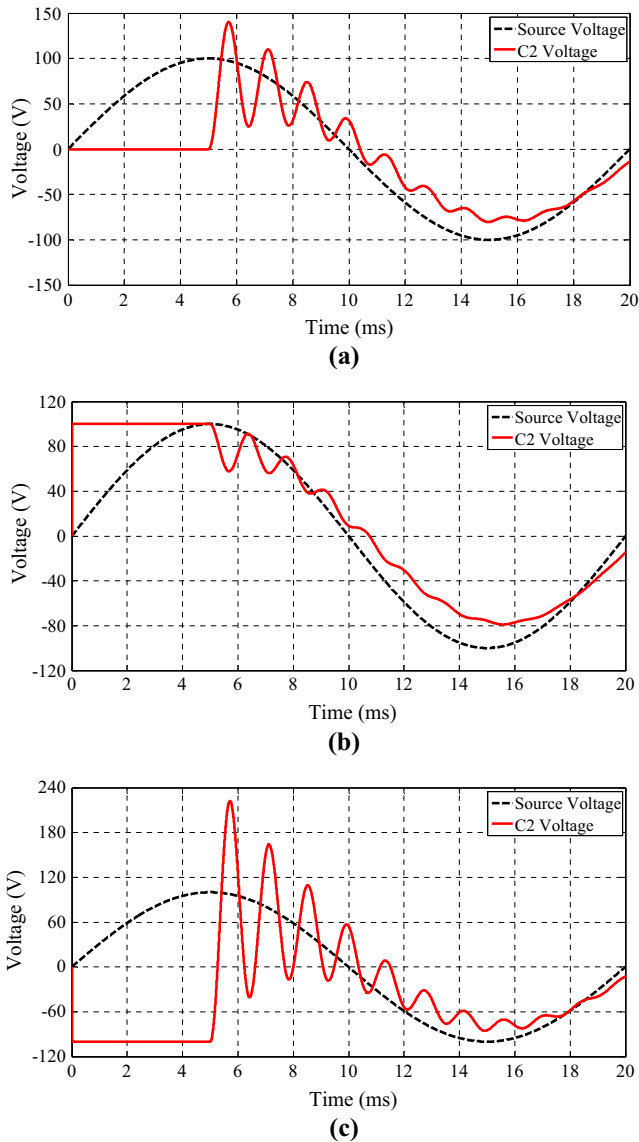

Fig. 5. The worst case capacitor switching at peak voltage (EMTP-RV).



**Fig. 6.** Capacitor switching at peak voltage (EMTP-RV) Case (a):  $V_c(0) = 0$ , Case (b):  $V_c(0) = +V_{max}$ , Case (c):  $V_c(0) = -V_{max}$ .

take place when the initial voltage of a capacitor is at the peak voltage and the closing switch in the reverse peak voltage. Fig. 6 shows three switching actions in which the initial voltages of capacitor bank are different. Besides, the flowchart depicted in Fig. 7 includes the procedure of solving the proposed problem in detail.

## 6. Simulation results

The proposed multi-objective capacitor placement method has been applied to the 9-bus and 85-bus radial test systems. In both case studies the capacitor placement candidate nodes were fixed based on the pre-planning studies. It should be noted that the proposed model has the ability to find the best location due to the introduced mapping procedure. Even if the candidate buses to install capacitors are pre-determined, the places of the capacitors are the variables of the problem. In fact, the selection of some candidate buses only limits the research space to a lower number of candidate buses to consider for the installation of capacitors. But, not all these candidate buses will be selected for the installation of capacitors by the proposed method. It should be noted that, tak-

ing into account selected candidate buses is common due to the fact that, in the real-world some buses may not have the minimum requirements of installing capacitors, such as enough space. Therefore, these buses should be eliminated from the space search of the optimization problem. It is considered that the locations for candidate capacitors are the same as in the literature [24,25,36,37]. In order to compare the methodology for evaluating optimal capacity placement problem, it is necessary to perform distribution power flow for each capacity placement plan. At the first step, the distribution system without the presence of fixed capacitors should be analyzed and the obtained results should be checked. In this study, the base case test system, in which the distribution system without fixed capacitors is considered, has been evaluated and the same results have been obtained as reported in Refs. [24,25,36]. This step confirms that the distribution power flow adopted in this study can overcome the radial features due to the resistance to reactance ratio (R/X). In this test system, the active and reactive loads are 12.368 MW and 4.186 MVar, respectively. So, it is necessary to manage the total reactive injection due to the capacitor placement. To do so, the maximum capacitor size has been limited to 4050 kVar in Refs. [24,25,36]. The life cycle for capacitors is considered to be 10 years and the maintenance and running costs are considered to be zero [24]. It is worth mentioning that the capacitor placement problem in such studies has been performed for one year the same as this study. In the aforementioned studies, the authors carried out the capacitor placement for pre-determined locations, i.e. buses 4, 5 and 9 [24,25,36]. Moreover, in Ref. [36] the authors have performed a sensitivity analysis for determining optimal locations of capacitor banks. However, the simulation results illustrated that almost all buses needs reactive compensation and the operator needs to install 9 MVar, but this amount is about two times greater than the reactive loads for end users. It seems that it is necessary to limit the total reactive compensation considering the total investment costs of capacitor banks. The first test system is considered to compare the results obtained by the proposed NSGA-II augmented by local search technique with the single objective model as reported in [25,36]. The second test system is a large scale radial network with laterals to confirm this fact that the proposed model could overcome the convergence challenge in large scale power distribution networks.

### 6.1. 9-bus test system

The first test system is a radial distribution feeder with nine load buses and its nominal substation transformer is rated at 15 MVA, 23 kV with impedance of  $(0.5 + j5)$  pu. It is desired to find the optimal values of three capacitors sizes to be placed at buses 4, 5 and 9.  $K^P$  was selected to be 168 \$/kW [38,39], and the limits on the rms voltages have been selected to be  $V_{min} = 0.9$  pu, and  $V_{max} = 1.1$  pu. It is worth noting that the data related to the yearly cost of fixed capacitors are provided in Ref. [25] while as reported in this reference, it is assumed that the substation voltage contains 4% and 3% of 5-th and 7-th harmonic, respectively, resulting in a total harmonic distortion of 5%. These harmonics orders are the most significant harmonics existing in distribution voltages besides the triplen (zero sequence) harmonics. It has been decided that the largest capacitor size  $Q_{max}^c$  should not exceed the total reactive load, i.e., 4186 kVar. In this study the loads have been modeled as PQ loads.

The maximum number of capacitors are 27 possible capacitor sizes while the related data along their corresponding annual cost/kVar are available in Ref. [24].

The simulation results in the same case have been confirmed by implementing the proposed power flow technique by using MAT-POWER package.



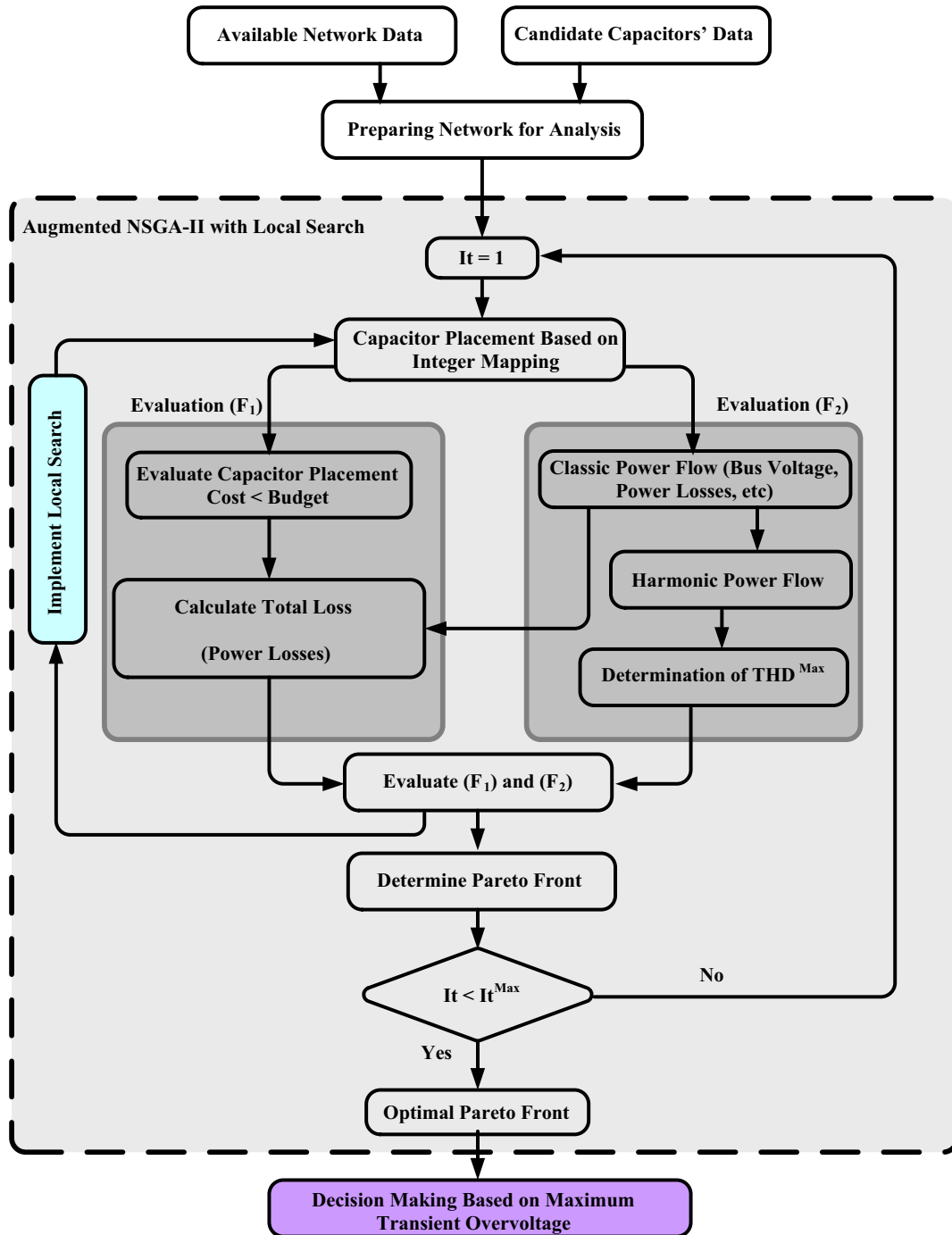

Fig. 7. The flowchart of the proposed framework.

The results reported in Ref. [24]. have been evaluated to validate the harmonic power flow equations in the presence of the mentioned capacitor banks. As can be seen in Table 2, the obtained results (A0) are in accordance with Ref. [24]. Having taken into consideration the significance of the power quality issues in electric power systems, the maximum THD ( $THD_{max}$ ) has been assigned to be equal to 5%. Moreover, a constraint has been assigned to the problem to limit the investment costs relating to the capacitor installation. In this respect, two different case studies have been considered where the maximum permitted investment cost are assigned to be 900 (\$) and 1000 (\$), respectively. It is worth noting that all data relating to the capacitor banks for a year,

taking into account the investment considerations, life time as well as the operation and management costs are available in Ref. [24]. Assuming constant load demand over all hours of a year, the power loss can be multiplied by the number of hours in a year and the respective cost (\$/kWh) to calculate the annual energy cost. As can be observed from Table 2, the results obtained including the investment limitation (Plan group B) are better in terms of  $THD_{max}$  and power losses if compared to the base case (A0). Besides, plan B1 is better in comparison with Plan A0 both from the  $THD_{max}$  and the capacity of capacitors viewpoints. Also, plan B2 dominates plan A0, since it has less power losses (about 73 kW) making it justifiable, although the installed capacity is the same as A0 and

**Table 2**  
Pareto front of capacitor placement in 9-bus test system.

Plan	$Q^g_c$ (kVAr)	$Q^s_c$ (kVAr)	$Q^f_c$ (kVAr)	Power Losses (kW)	THD <sub>max</sub>	Total_Cap (kVAr)	Total_Inv (\$)	
A0	2100	0	2850	822.581	4.918	4950	891.150	Ref. [24]
B1	0	3000	1650	743.812	4.680	4650	858.150	Investment Cost Constraint = 900 (\$)
B2	0	3300	1650	749.507	4.651	4950	892.650	
C1	1200	2550	1500	723.999	4.709	5250	987.450	Investment Cost Constraint = 1000 (\$)
C2	900	2400	2100	770.128	4.450	5400	942.300	
C3	1200	2400	1800	743.276	4.459	5400	948.600	
C4	450	3300	1500	738.202	4.460	5250	989.550	
C5	600	3000	1500	732.053	4.671	5100	973.500	
C6	900	2850	1500	729.156	4.681	5250	987.750	

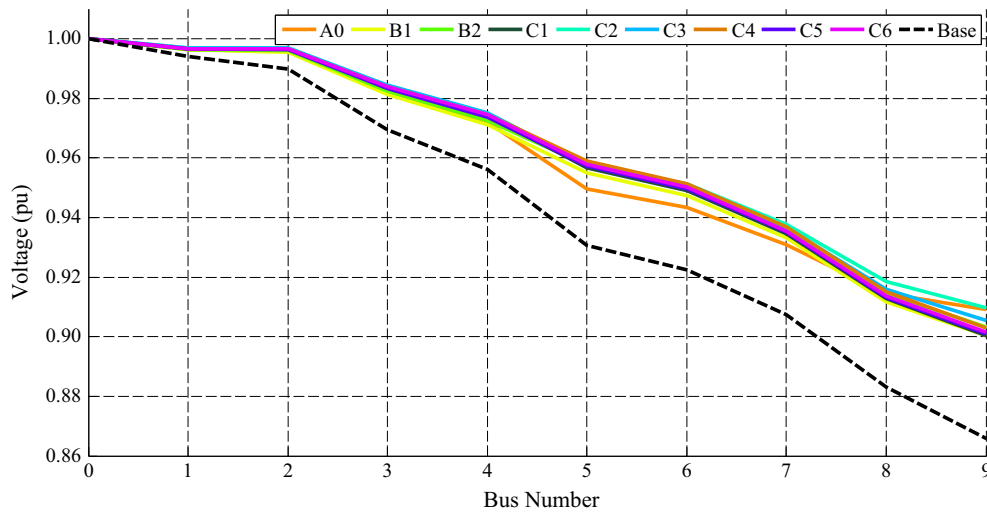

**Fig. 8.** Voltage profile of 9-bus test system.

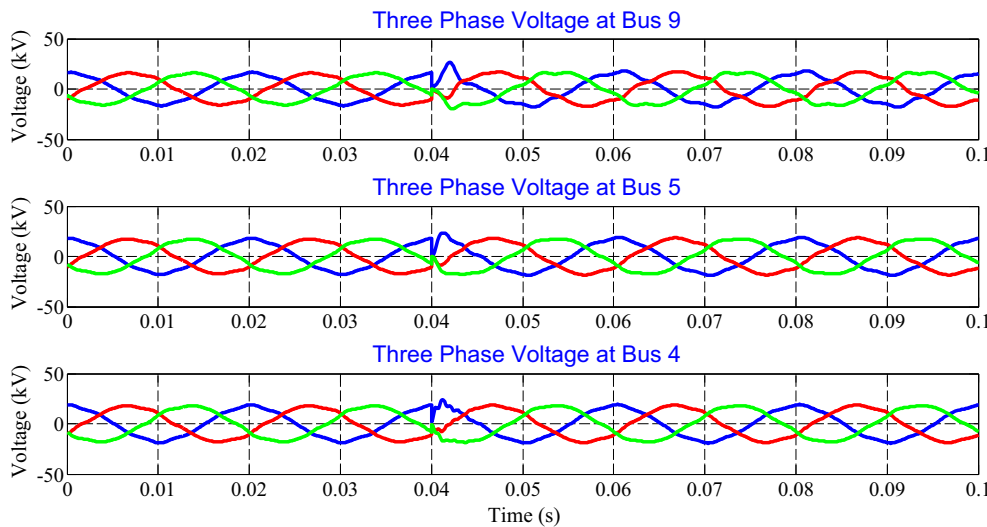

**Fig. 9.** Maximum transient over voltage due to capacitor placement (Plan C6).

the investment cost is higher by 1.5 (\$). In plan group C, the limitation of the investment cost has been assigned 1000 (\$) leading to six plans, C1-C6. In this regard, the lower loss is equal to 723.999 (kW) in plan C1 and the lower THD<sub>max</sub> relates to Plan C2 and it is equal to 4.45. The capacity of capacitors varies from 5100 (kVAr) to 5400 (kVAr). Taking into consideration the close obtained results, the next step would be evaluating the transient overvolt-

ages to pick up the best compromise solution amongst the derived solutions. Fig. 8 shows the voltage profile in different buses before and after installing the capacitors for the best compromise plan.

Based on the reported cases in Ref. [25], the maximum allowed THD<sub>max</sub> for voltage at the load buses has been considered to be below 8% and 5%. In the multi-objective framework, only the under 5% of THD<sub>max</sub> can be seen and another plan has been dominated.

The simulation results for multi-objective evaluation of functions are reported in Table 2 including both THD<sub>max</sub> and power losses in the presence of optimum capacitor placement for each member of Pareto solutions. Fig. 8 illustrates the voltage profile of 9-bus test system for these Pareto solutions.

After the determination of the Pareto set, in the decision making stage, the severe transient over voltage should be evaluated to attain the minimum over voltage in the executive plan. In order to perform the transient simulation study, the EMTP-RV package has been applied. The severe condition for transient over voltage has been addressed in the Section 5.

The time domain simulation results for the worst case and the best case are provided in Figs. 9 and 10, respectively. In these figures, the capacitor banks switching has been performed for different initial voltage stored in capacitors, because the amount of the stored charges in capacitors are unknown. It is worth mentioning that these results are obtained corresponding to three different states depicted in Fig. 6. In such circumstances, in order to consider the severe conditions, the switching actions for all installed capacitor have been applied at the same time.

The simulation results claim that the maximum over voltages would exactly occur at the location of the installed capacitor banks.

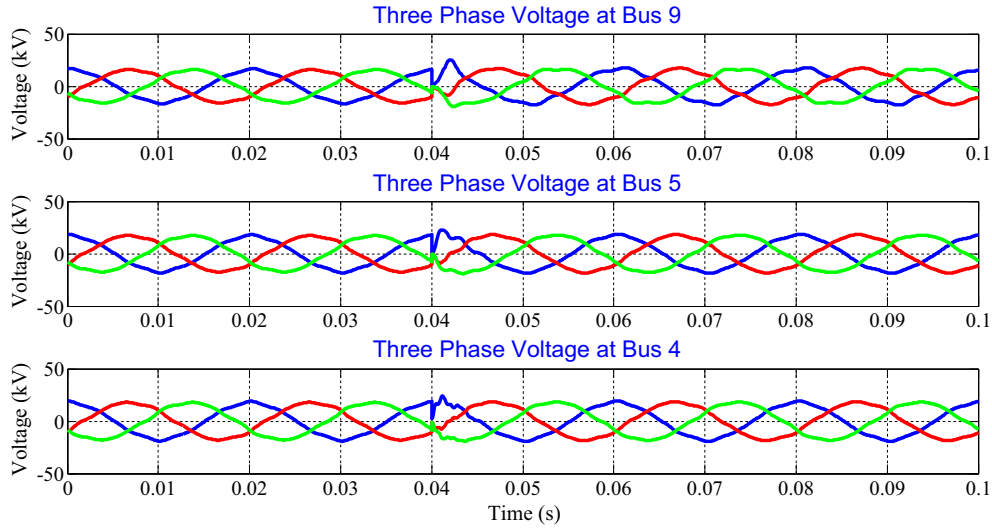

Fig. 10. Minimum transient over voltage due to capacitor placement (Plan C2).

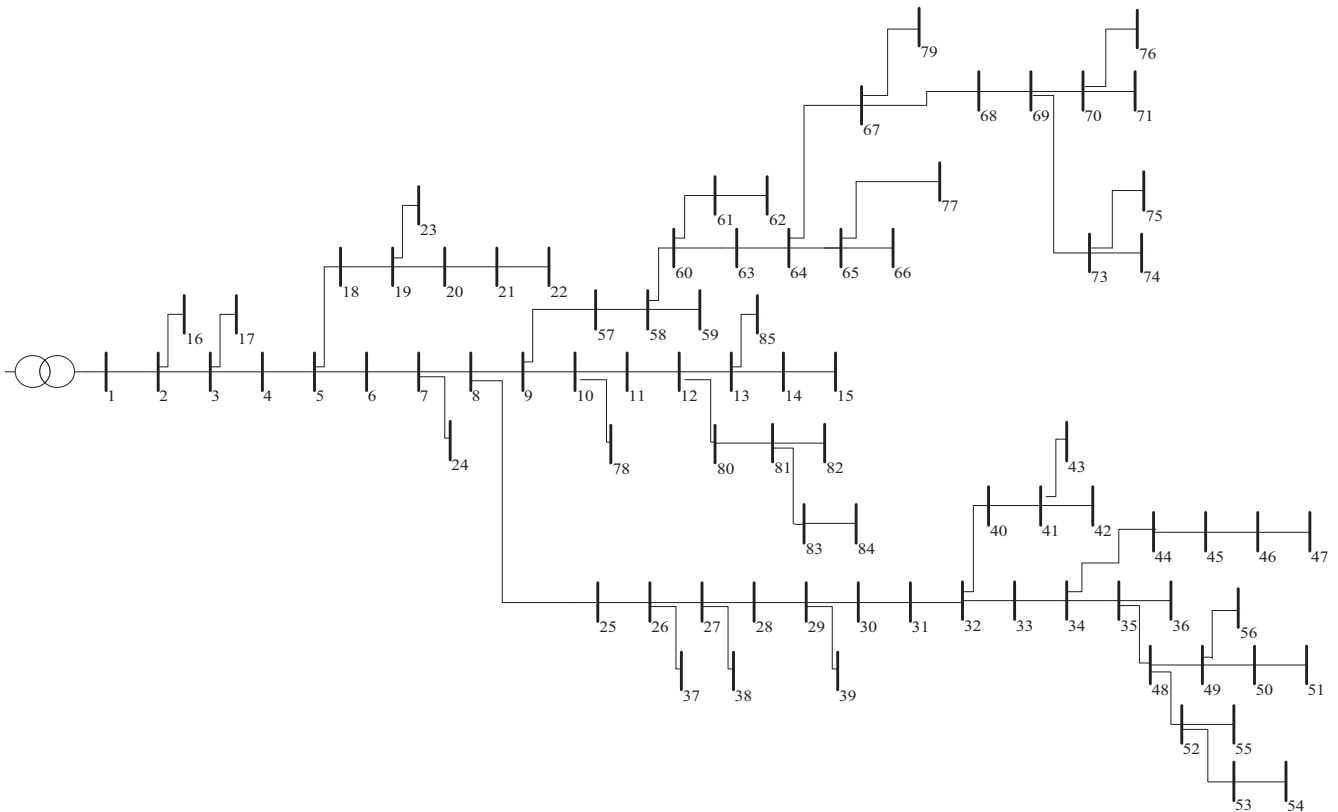

Fig. 11. Single line diagram of 85-bus test system [40].

The main reason of this issue is X/R ratio of distribution networks. The resistance of distribution feeders is greater than those for transmission lines. Therefore, the damping criterion of overvoltage for distribution networks is considerable. Moreover, the large amounts of low voltage loads are residential and commercial and the percentages of industrial loads are negligible. As a result, the presence of multiple capacitor banks in a radial network, the transient overvoltage due to simultaneous capacitor switching would be considerable.

However, the THD<sub>max</sub> in this case is 4.9% which is lower than other plans. It is worth mentioning that the minimum over voltage of simultaneous capacitor switching is 25.3134 kV in plan C2 and the maximum over voltage is 26.4429 kV in plan C6. It is also noted that according to Ref. [24], the power losses before the capacitor placement are 783.3 kW while after the capacitor placement, the power losses are 770.128 kW.

### 6.2. 85-bus test system

The second case study has 85 buses. This test system has been considered to implement the proposed method on a large scale test system. The single diagram of 85-bus test system is illustrated in Fig. 11. As it is evident from the single line diagram, the 85-bus test system has different laterals. The load models in this study consist of all reported models as represented in Table 1.

Commercially-available capacitor sizes in this case are the same as the ones considered in the previous case study while the branch data have been reported in Ref. [40]. The hourly net demand (hourly load) and the injected power from the grid (the load demand plus the power losses) for this test system is provided in Fig. 12.

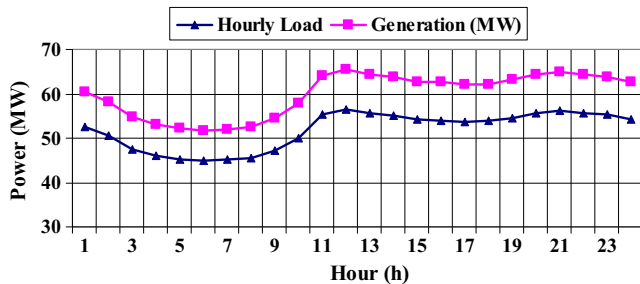

Fig. 12. Demand and generation power trends for daily peak load.

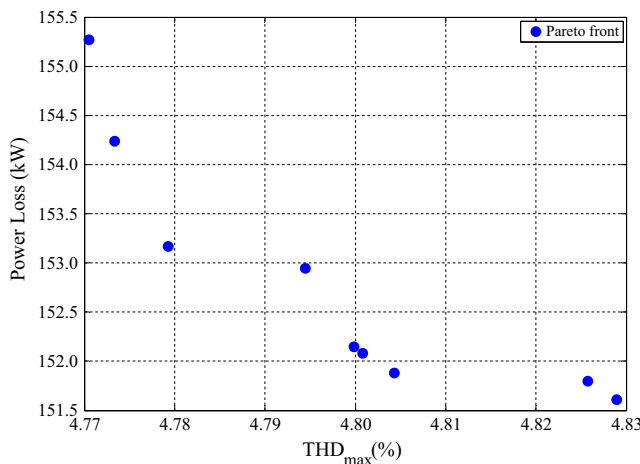

Fig. 13. Optimal Pareto front for the 85-bus test system.

**Table 3**  
Selected plans based on THD<sub>max</sub> = 5% and associated maximum transient over voltage.

Plan	Maximum Over Voltage (kV)	Occurrence Location (Bus)	Occurrence Time (h)
1	26.54	8	13
2	27.24	60	12
3	25.65	8	14
4	27.03	60	15
5	26.67	60	10
6	26.13	9	21
7	26.10	9	22
8	25.89	34	23
9	25.71	34	24

The difference between the generation and demand represents the hourly power losses. The limits on the rms voltages have been selected to be V<sub>min</sub> = 0.9 pu, and V<sub>max</sub> = 1.1 pu. One of the key features considered in this case study is to take into consideration the peak seasonal loads. As the capacitor placement in distribution networks is a long-term planning issue and on the other hand, the operation of such compensating devices depends upon the short-term operation of power systems, it is necessary to perform the simulations at the severe operational conditions.

It is desired to find the optimal values of three capacitor sizes (k = 7) to be placed at buses 7, 8, 9, 29, 34, 58 and 60. The capacitor sizes and the cost per unit of the power losses are the same as the previous case study. Consequently it is needed to evaluate the 27 integer decision variables and also the associated local search technique should be applied in NSGA-II to determine the best Pareto optima. However, the candidate locations are greater than the 9-bus test system but the mapping procedure is the same as the one mentioned above. The Pareto front for this test system includes 9 Pareto solutions (plans).

Fig. 13 illustrates the Pareto front related to the 85-bus test system capacity placement. In this test system, the maximum allowed THD is limited to be below 5% and the maximum investment cost limited to be lower than 700 (\$/year). Therefore, only 9 plans remain for transient overvoltage evaluations.

Since the final plans are limited to 9 plans, it is necessary to perform 24 simulations based on hourly trends of loads. The demand includes the industrial, commercial and residential loads and each of them has different types of load model mentioned in Table 1.

Table 3 addresses the maximum overvoltages due to capacitor switching and associated occurrence intervals. Simulation results show that plan 3 has the lowest maximum overvoltage due to capacitor switching and the maximum overvoltage of 25.65 kV happens at hour 14. It is worth mentioning that the rated voltage of this test system is 20 kV. The voltage profile of the system for different plans has been depicted in Fig. 14. According to Ref. [41], the power losses before placement of the capacitors are 315.714 kW, while after placement of the capacitors, the power losses are 153.2 kW.

### 6.3. Discussion

As general results, the following observations can be considered:

- 1- The maximum overvoltages occur at hours with peak load demand.
- 2- The buses at which the overvoltage occurs include the inductive loads as well as the induction machines such as buses 8 and 60.
- 3- It is noted that fluorescent lighting load (at Bus 10) can impact the overvoltage during capacitor switching, such as the one observed at Bus 9 at hour 21 and 22.

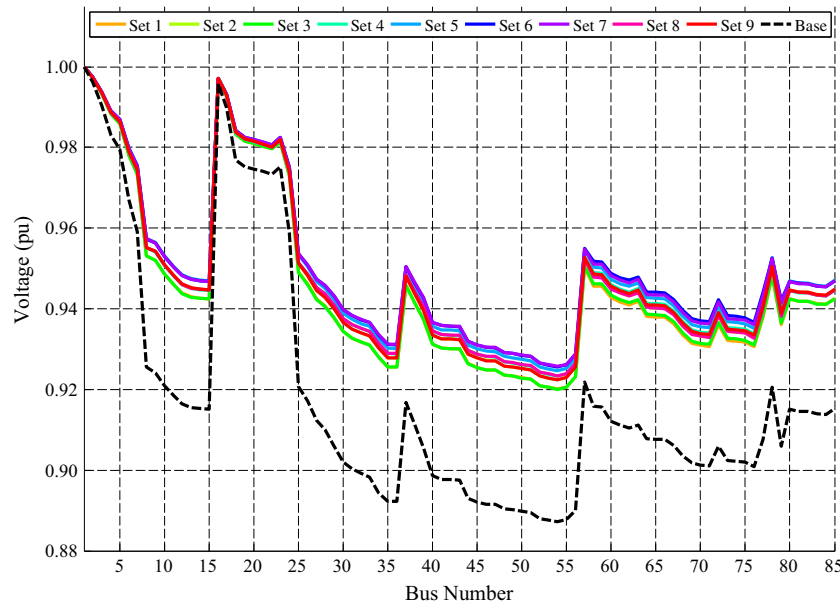

Fig. 14. Voltage profile of 85-bus test system.

With respect to this fact the first stage decision variables are binary and also the limited number of states, applying other heuristic optimization methods, such as Multi-objective Particle Swarm Optimization (MOPSO) may lead to the same results as NSGA-II. In addition, it is noted that the sub-problems solutions for THD calculation, load flow and the associated capital cost are all deterministic. Therefore, these items would not affect the outputs of the sub-problem of the optimization level as well as the transient overvoltage evaluation. In brief, it can be stated that the decision vector at the first stage results in the unique solution which is deterministic.

## 7. Conclusion

This paper provides a new approach in capacitor placement in radial distribution network aiming to reduce power losses and ensure the total harmonic distortion maintaining the power quality issues. Moreover, in this study we considered the transient overvoltage criterion due to capacitor switching in the network. This criterion has been modeled as a decision making support technique to select the best plan from the optimal Pareto front provided by the modified NSGA-II. The addressed NSGA-II in this research was augmented with the local search technique to improve the convergence time and accelerate the problem evaluation. In the proposed method, we adopted the local search for sizing part of chromosomes of NSGA-II. The addressed technique could be implemented in other discrete-variables optimization problems such as generation and transmission expansion planning problems. The simulation results in the case studies confirmed that with the presence of multiple capacitor banks in a radial network, the transient overvoltage due to simultaneous capacitor switching would be considerable. Moreover, in multiple capacitor placements, the rising transient overvoltage in switching of each capacitor bank is greater than those one for a centralized capacitor with the same capacitor located at a same node.

## Acknowledgment

J.P.S. Catalão acknowledges the support by FEDER funds through COMPETE 2020 and by Portuguese funds through FCT,

under Projects SAICT-PAC/0004/2015 - POCI-01-0145-FEDER-016434, POCI-01-0145-FEDER-006961, UID/EEA/50014/2013, UID/CEC/50021/2013, and UID/EMS/00151/2013, and also funding from the EU 7th Framework Programme FP7/2007-2013 under GA no. 309048.

## References

- [1] Sayed AG, Youssef HKM. Optimal sizing of fixed capacitor banks placed on a distorted interconnected distribution networks by Genetic Algorithms. Computational Technologies in Electrical and Electronics Engineering, 2008 SIBIRCON 2008 IEEE Region 8 international conference on; 2008. p. 180–5.
- [2] Kalyuzhny A, Levitin G, Elmakis D, Ben-Haim H. System approach to shunt capacitor allocation in radial distribution systems. *Electric Power Syst Res* 2000;56:51–60.
- [3] Levitin G, Kalyuzhny A, Shenkman A, Chertkov M. Optimal capacitor allocation in distribution systems using a genetic algorithm and a fast energy loss computation technique. *IEEE Trans Power Delivery* 2000;15:623–8.
- [4] Ware J. Power factor correction. *IEE Wiring Matters* 2006:22–4.
- [5] Schultz AJ, Johnson IB, Schultz NR. Magnification of switching surges. *Electr Eng* 1959;78:811.
- [6] Ramasamy N. *Power systems capacitors*. New York: Taylor & Francis; 2005.
- [7] McGranaghan MF, Zavadi RM, Hensley G, Singh T, Samotyj M. Impact of utility switched capacitors on customer systems-magnification at low voltage capacitors. *IEEE Trans Power Delivery* 1992;7:862–8.
- [8] Das JC. Analysis and control of large-shunt-capacitor-bank switching transients. *IEEE Trans Ind Appl* 2005;41:1444–51.
- [9] Olivier G, Mougharbel I, Dobson-Mack G. Minimal transient switching of capacitors. *IEEE Trans Power Delivery* 1993;8:1988–94.
- [10] Aradhya RS, Subash S, Meera KS. Evaluation of switching concerns related to shunt capacitor bank installations. *International conference on power system transients*. London; 1995.
- [11] Coury DV, dos Santos Cu J, Oleskovicz Mr, Tavares MC. Transient analysis concerning capacitor bank switching in a distribution system. *Electric Power Syst Res* 2003;65:13–21.
- [12] El-Ela AAA, El-Sehiemy RA, Kinawy AM, Mouwafi MT. Optimal capacitor placement in distribution systems for power loss reduction and voltage profile improvement. *IET Gener Transm Distrib* 2016;10:1209–21.
- [13] Abdelaziz AY, Ali ES, Abd Elazim SM. Flower pollination algorithm and loss sensitivity factors for optimal sizing and placement of capacitors in radial distribution systems. *Int J Electr Power Energy Syst* 2016;78:207–14.
- [14] Ali ES, Abd Elazim SM, Abdelaziz AY. Improved harmony algorithm and power loss index for optimal locations and sizing of capacitors in radial distribution systems. *Int J Electr Power Energy Syst* 2016;80:252–63.
- [15] Huang SJ, Liu XZ. A plant growth-based optimization approach applied to capacitor placement in power systems. *IEEE Trans Power Syst* 2012;27:2138–45.
- [16] Othman AM. Optimal capacitor placement by Enhanced Bacterial Foraging Optimization (EBFO) with accurate thermal re-rating of critical cables. *Electric Power Syst Res* 2016;140:671–80.



- [17] Vuletić J, Todorovski M. Optimal capacitor placement in distorted distribution networks with different load models using Penalty Free Genetic Algorithm. *Int J Electr Power Energy Syst* 2016;78:174–82.
- [18] Soroudi A, Amraee T. Decision making under uncertainty in energy systems: State of the art. *Renew Sustain Energy Rev* 2013;28:376–84.
- [19] Eminoglu U, Hocaoglu MH. A new power flow method for radial distribution systems including voltage dependent load models. *Electric Power Syst Res* 2005;76:106–14.
- [20] Taylor CW. *Power system voltage stability*. McGraw-Hill; 1994.
- [21] Cutsem TV, Vournas CD. *Voltage stability of electric power systems*. Kluwer; 1998.
- [22] Dous GL. *Voltage stability in power systems. Load modeling based on 130 kV field measurements*. Goteborg, Sweden: Department of Electrical Power Engineering, Chalmers University of Technology; 1999.
- [23] Bortignon GA, El-Hawary ME. A review of capacitor placement techniques for loss reduction in primary feeders on distribution systems. *Electrical and computer engineering, 1995 Canadian conference on*, vol. 2; 1995. p. 684–7.
- [24] Baghzouz Y, Ertem S. Shunt capacitor sizing for radial distribution feeders with distorted substation voltages. *IEEE Trans Power Delivery* 1990;5:650–7.
- [25] Khalil TM, Youssef HKM, Abdelaziz MM. Optimal capacitor placement on radial distribution feeders in presence of nonlinear loads using binary particle swarm optimization. 19th International conference on electricity distribution (CIRED 2007). Vienna 2007. p. Paper 180.
- [26] Deb K, Pratap A, Agarwal S, Meyarivan T. A fast and elitist multiobjective genetic algorithm: NSGA-II. *IEEE Trans Evolut Comput* 2002;6:182–97.
- [27] Pires DF, Antunes CH, Martins AG. NSGA-II with local search for a multi-objective reactive power compensation problem. *Int J Electr Power Energy Syst* 2012;43:313–24.
- [28] Deb K. *Multi-objective optimization using evolutionary algorithms*. New York: Wiley; 2003.
- [29] Soroudi A, Afrasiab M. Binary PSO-based dynamic multi-objective model for distributed generation planning under uncertainty. *IET Renew Power Gener* 2012;6:67–78.
- [30] Debnath D, De A, Chakrabarti A, Kothari DP. Studies on the impact of capacitor bank switching on grid connected transformers. *Int J Electr Power Energy Syst* 2012;43:126–30.
- [31] Greenwood A. *Electrical transients in power systems*. John Wiley & Sons; 1991.
- [32] Grebe T. Application of distribution system capacitor banks and their impact on power quality. *IEEE Trans Ind Appl* 1996;32:714–9.
- [33] Witte JF, DeCesaro FP, Mendis SR. Damaging long-term overvoltages on industrial capacitor banks due to transformer energization inrush currents. *IEEE Trans Ind Appl* 1994;30:1107–15.
- [34] Cran A. Investigation into harmonics and switching transients at substations equipped with Capacitor banks using ATP software. 2000.
- [35] Sickle RCV, Zaborszky J. Capacitor switching phenomena. *Electr Eng* 1952;71:126.
- [36] Khalil TM, Youssef HKM, Aziz MMA. A binary particle swarm optimization for optimal placement and sizing of capacitor banks in radial distribution feeders with distorted substation voltages. *AIML 06 International conference*. Sharm El Sheikh, Egypt; 2006. p. 129–35.
- [37] Ameli K, Alfi A, Aghaebrahimi M. A fuzzy discrete harmony search algorithm applied to annual cost reduction in radial distribution systems. *Eng Optim* 2016;48:1529–49.
- [38] Grainger JJ, Lee SH. Optimum size and location of shunt capacitors for reduction of losses on distribution feeders. *IEEE Trans Power Apparatus Syst* 1981;PAS-100:1105–18.
- [39] Ramadan HA, Wahab MAA, El-Sayed A-HM, Hamada MM. A fuzzy-based approach for optimal allocation and sizing of capacitor banks. *Electric Power Syst Res* 2014;106:232–40.
- [40] Das D, Kothari DP, Kalam A. Simple and efficient method for load flow solution of radial distribution networks. *Int J Electr Power Energy Syst* 1995;17:335–46.
- [41] Rao RS, Narasimham SVL, Ramalingaraju M. Optimal capacitor placement in a radial distribution system using Plant Growth Simulation Algorithm. *Int J Electr Power Energy Syst* 2011;33:1133–9.