

# Reactive Power Control Using FC-TCR

Ms. Shilpa Gupta  
EN Dept.  
Inderprastha Engineering College  
Ghaziabad, INDIA

**Abstract:** This paper will discuss and demonstrate how Static Var Compensator (SVC) has successfully been applied to control transmission systems dynamic performance for system disturbance and effectively regulate system voltage. SVC is basically a shunt connected static var generator whose output is adjusted to exchange capacitive or inductive current so as to maintain or control specific power variable. For this a Single Machine Infinite Bus (SMIB) system is modeled. In this paper, simple circuit model of Thyristor Controlled Reactor is modeled and simulated using MATLAB. The simulation results are presented. The current drawn by the TCR varies with the variation in the firing angle. The simulation results are compared with the theoretical results.

**Key Words:** Static VAR Compensators, FC-TCR, MATLAB, Simulink, Reactive Power.

## I. INTRODUCTION

Electricity demand is increasing continuously. To fulfill this rise, the increase in generation is need of hour, which is not always feasible due to various constraints such as environmental, financial, time, availability of resources, land etc. Also expansion of transmission system is always not possible. Due to these restrictions the whole power system is working to their maximum capacity which can lead to instability and blackouts under any severe fault conditions. To provide stable, secure, controlled, high quality electric power on today's environment and to do better utilization of available power system capacities Flexible AC transmission systems (FACTS) controllers are employed to enhance power system stability[1,2] in addition to their main function of power flow control.

The Power electronic based FACTS devices are added to power transmission and distribution systems at strategic locations to improve system performance. FACTS are a family of devices which can be inserted into power grids in series, in shunt, and in some cases, both in shunt and series. FACTS mainly find applications in the following areas:

- Power transmission
- Power quality
- Railway grid connection
- Wind power grid connection
- Cable systems

With FACTS, the following benefits can be attained in AC systems:

- Improved power transmission capability
- Improved system stability and availability
- Improved power quality

- Minimized environmental impact
- Minimized transmission losses

Due to nature of power electronics equipment, FACTS devices are applicable for one or more of the following qualities:

- Rapid dynamic response.
- Ability for frequent variations in output.
- Smoothly adjustable output.

FACTS are a family of devices which can be inserted into power grids in series, in shunt, and in some cases, both in shunt and series.

### A. Shunt Device

- (1) Static Var Compensator:
- (2) Static Synchronous Compensator (STATCOM)

### B. Series Device

- (1) Thyristor Controlled Series Compensator (TCSC)
- (2) Static Synchronous Series Compensator (SSSC)

Important applications in power transmission and distribution involve devices such as SVC (Static Var Compensators), Fixed Series Capacitors (SC) as well as Thyristor-Controlled Series Capacitors (TCSC) and STATCOM.

## II. STATIC VAR COMPENSATOR (SVC)

Static VAR systems are applied by utilities in transmission applications for several purposes. The primary purpose is usually for rapid control of voltage at weak points in a network. Installations may

be at the midpoint of transmission interconnections or at the line ends [3]. Static Var Compensators are shunt connected static generators / absorbers whose outputs are varied so as to control voltage of the electric power systems.

An SVC can improve power system transmission and distribution performance in a number of ways. Installing an SVC at one or more suitable points in the network can increase transfer capability and reduce losses while maintaining a smooth voltage profile under different network conditions. The dynamic stability of the grid can also be improved, and active power oscillations mitigated [4,5]. To summarize the application of SVC gives the following benefits.

In power transmission:

- Stabilized voltages in weak systems
- Reduced transmission losses
- Increased transmission capacity, to reduce or remove the need for new lines
- Higher transient stability limit
- Increased damping of minor disturbances
- Greater voltage control and stability
- Power swing damping

In power distribution:

- Stabilized voltage at the receiving end of long lines
- Increased productivity as stabilized voltage better utilizes capacity
- Reduced reactive power consumption, gives lower losses and eliminates higher or penalty tariffs
- Balanced asymmetrical loads reduce system losses
- Fewer stresses in asynchronous machinery
- Enables better use of equipment (particularly transformers and cables)
- Reduced voltage fluctuations and light Flicker

An SVC fig. 1 typically comprises a transformer, reactors, capacitors and bi-directional thyristor valves. There is a variety of main circuit arrangements.

- FC/TCR – Fixed Capacitor (filter) / Thyristor-Controlled Reactor.
- TSC/TCR–Thyristor-Switched Capacitors/Thyristor-Controlled Reactor.

In its simple form, SVC is connected as Fixed Capacitor-Thyristor Controlled Reactor (FC-TCR) configuration as shown in Fig. 2.

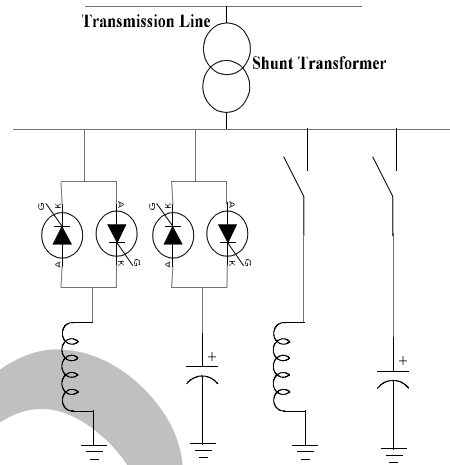

Figure. 1 Functional diagram of SVC

### III. MODELING OF FC-TCR

The control objective of SVC is to maintain the desired voltage at a high voltage bus [6, 7]. In steady-state, the SVC will provide some steady-state control of the voltage to maintain it the highest voltage bus at the pre-defined level.

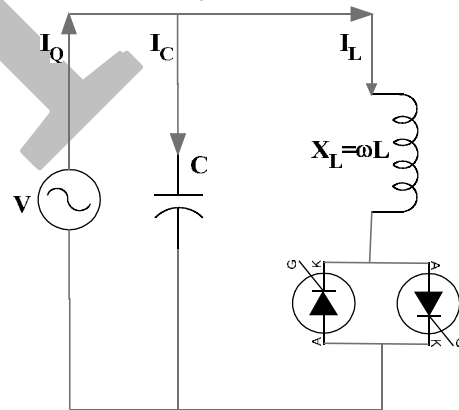

Figure 2 Basic FC-TCR type static var compensator

If the voltage bus begins fall below its set point range, the SVC will inject reactive power (Q net) into the system (within its control limits), thereby increasing the bus voltage back to its desired voltage level. If bus voltage increases, the SVC will inject less (or TCR will absorb more) reactive power (within its control limits), and the result will be to achieve the desired bus voltage.

The Fixed Capacitor Thyristor-Controlled Reactor (FC-TCR)[8] is a var generator arrangement using a fixed (permanently connected) capacitance with a thyristor controlled reactor as shown in Fig.2

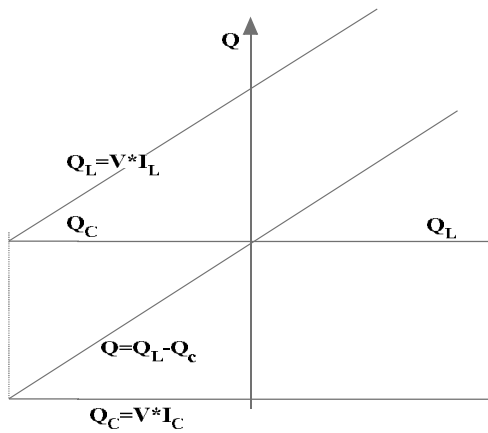

Figure 3 Vars demand V/S Vars output characteristic

The current in the reactor is varied by the method of firing delay angle control method. The constant capacitive var generation ( $Q_c$ ) of the fixed capacitor is opposed by the variable var absorption ( $Q_L$ ) of the thyristor controlled reactor, to yield the total var output ( $Q$ ) required fig.3. At the maximum capacitive var output, the thyristor-controlled reactor is off [9 -

11]. To decrease the capacitive output, the current in the reactor is increased by decreasing delay angle  $\alpha$ . At zero var output, the capacitive and inductive currents become equal and thus both the vars cancels out.

With further decrease of angle  $\alpha$ , the inductive current becomes larger than the capacitive current, resulting in a net inductive output.

#### IV. SIMULATION RESULTS AND DISCUSSIONS

For the AC voltage source is of 11KV, 60 Hz, line  $R=5\Omega$  &  $L=60mH$ , Load  $R=1\Omega$  &  $L=50mH$ . Current measurement block is used to measure the instantaneous current flowing in the transmission line. The voltage measurement block is used to measure the source voltage. Scope displays the signals generated during a simulation. In Fig.5, scope is used to view the line current and in Fig.6 line voltage. The real power and reactive power in the load is measured using the Active & Reactive Power measurement block. ac source voltage.

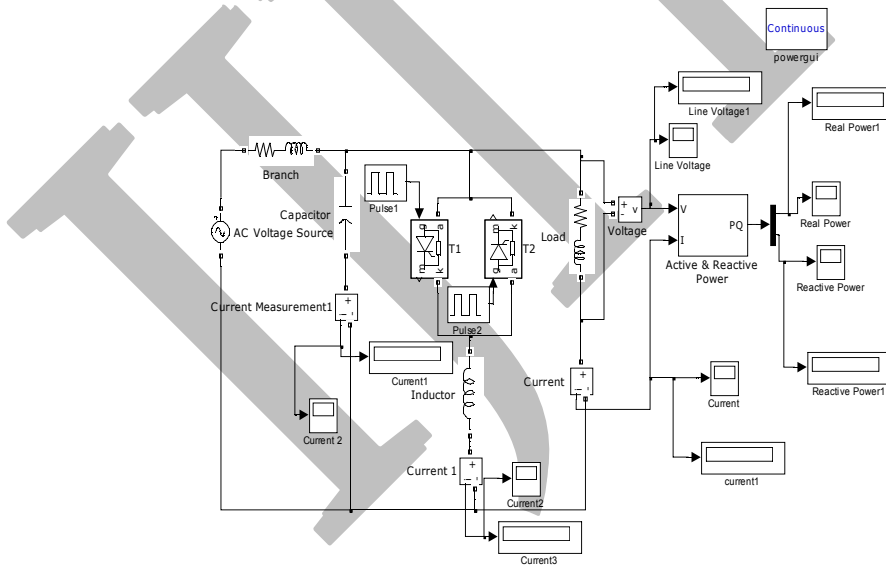

Figure 4 MATLAB Simulink Model of FC- TCR

Given are the figures illustrating the waveforms after simulating the model.

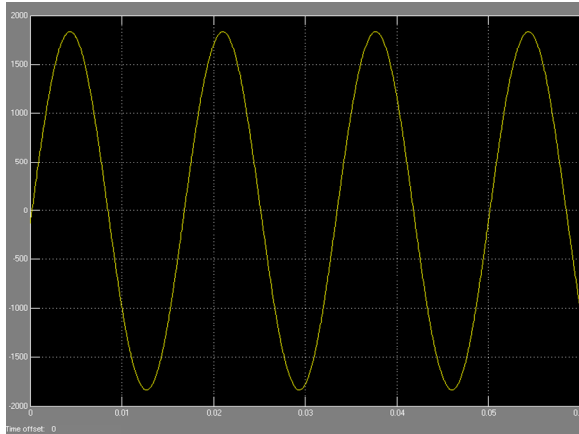

Figure 5: Line Current



Figure 6: Line Voltage

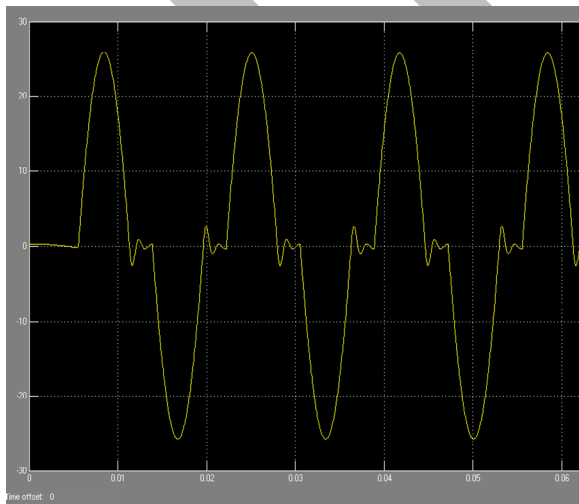

Figure 7: TCR Reactor Current

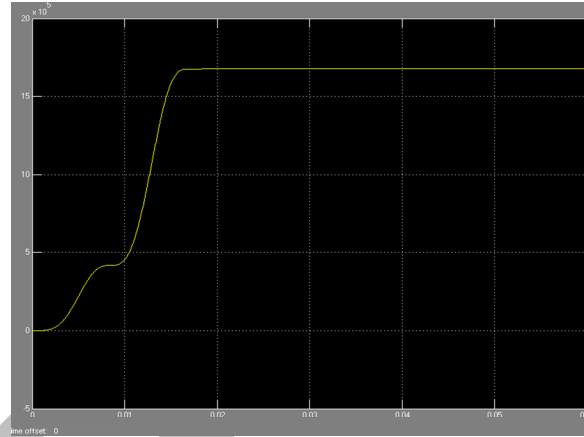

Figure 8: Real Power

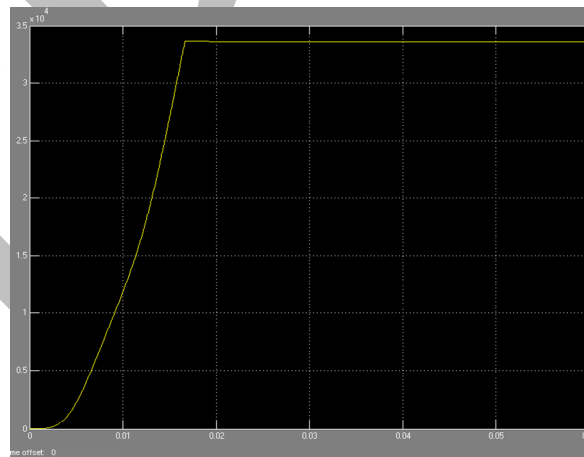

Figure 9 :Reactive Power

Table 1: Capacitor Constant & Inductance varying

C (micro F)	L (mH)	Q(VAR)
100	100	33590
100	150	33610
100	200	33620
100	250	33630
100	300	33650

Table 2: Variation of TCR Current and Reactive Power for different firing angles

Firing Angle (degree)	Current through TCR	Q(VAR)
30°	90	33570
60°	78	33580
90°	50	33600
120°	22	33620
150°	7	33640
180°	0	33650

## V. TEST RESULTS

From Table 1 we can see that if we keep capacitor value as constant and vary the value of inductor then reactive power is increasing and from Table 2 we can conclude that if increase firing angle current through TCR decreases with increase of firing angle thereby increasing the Reactive Power output. This shows that reactive power is compensated and hence stability of power system is improved.

## VI. CONCLUSION

Hence it is concluded that SVC (Static VAR Compensator) will successfully control the dynamic performance of power system and voltage regulation of the power system. The variation of reactive power with the variation in the firing angle is studied. The range of reactive power control can be increased by using the combination of thyristor controlled reactor and fixed capacitor system. The circuit model for FC-TCR is obtained and the same is used for simulation using MATLAB Simulink. From the simulation studies it is observed that the reactive power variation is smoother by using FC TCR system. Reactive power drawn by the load increases with FC-TCR since the bus voltage increases. The simulation results are almost similar to the theoretical results.

## VII. REFERENCES

1. Nang Sabai, and Thida Win "Voltage control and dynamic performance of power transmission system using SVC" *World Academy of Science, Engineering and Technology* Pp. 425-429 2008.
2. Eric Allen, Niels LaWhite, Yong Yoon, Jeffrey Chapman, and Marija Ilic, "Interactive Object-Oriented Simulation of Interconnected Power Systems Using SIMULINK", *IEEE Transactions on Education*, vol. 44, no. 1, Feb. 2001.
3. D. Murali, "Comparison of FACTS devices for power system stability enhancement", *International Journal of Computer Applications (0975 – 8887) Volume 8– No.4, Pp. 30-35, Oct 2010.*
4. Bindeshwar Singh, N.K Sharma and A.N Tiwari, "A comprehensive survey of coordinated control techniques of FACTS controllers in multi machine power system environments", *International Journal of Engineering Science and Technology* Vol. 2(6), 1507-1525, 2010.
5. M.A Abibo, "Power System stability enhancement using FACTS controllers", *The Arabian Journal for Science and Engineering* Volume 34, Pp. 153-161.
6. R. M. Mathur and R. K. Varma, "Thyristor Based FACTS Controller for Electrical Transmission System", *IEEE Press*, 2002.
7. R. Toyoshima, T. Funaki, and T. Hikiyara, "Anomalous phenomena of conduction angle in TCR-SVC and its control," in *Proc. IEEE 35<sup>th</sup> Ann. Power Electronics Specialists Conf.*, vol. 2, pp. 3403-3408, Aachen, Germany, 20-25 Jun. 2004.
8. F. Z. Gherbi, S. Hadjeri, and F. Ghezal, "Modeling and simulation of static var compensator with Matlab," in *Proc. 4th Int. Conf. on Computer Integrated Manufacturing, CIP'2007.*
9. T. Y. Gelen, "Analysis of TSR-based SVC for a three-phase system with static and dynamic loads," in *Proc. of the IEEE Int. Conf. on Electrical Engineering, ICEE'07*, 6 pp., Lahore, Pakistan, 11-12 Apr. 2007.
10. T. Y. Gelen, "The behavior of TSR-based SVC and TCR-based SVC installed in an infinite bus system," in *Proc. IEEE 25th Convention Electrical and Electronics Engineers in Palestine*, pp. 120-124, 3-5 Dec. 2008.
11. Gutierrez, J, Montano, J.C, Castilla, M. and Lopez, A. "Power-quality improvement in reactive power control using FCTCR circuits", *IECON 08, Industrial Electronics Society, IEEE 2008, 28th Annual Conference, Volume 2, 5-8 pp.:880 - 885 vol.2.*
12. Patricio Mendoza-Araya, Jaime Muñoz Castro, Jaime Cotos Nolasco, and Rodrigo E. Palma-Behnke, "Lab-Scale TCR-Based SVC System for Educational and DG Applications", *IEEE Transactions on Power Systems*, vol. 26, no. 1, Feb. 2011.
13. T.Vijayakumar, .A.Nirmalkumar, "Harmonics Analysis of Thyristor controlled Reactor circuits", *International Journal of Computer and Electrical Engineering*, Vol. 2, No. 1, February, 2010.
14. T.Vijayakumar, A.Nirmalkumar and N.S. Sakthivelmurugan, "Reactive Power Control Using FC -TSR – TCR", *Research Journal of Applied Sciences, Engineering and Technology* 2(1): 1-4, January 05, 2010.